

FTTH Applications

FTTH ONT (Optical Network Terminal)

Description

One of the greatest challenges facing service providers is how to deploy triple-play services quickly and cost-effectively in order to start building revenue.

To assist service providers, Scientific Atlanta has developed a FTTH ONT (fiber-to-the-home optical network terminal) for Ethernet & Video - an indoor customer premises device that will serve as the network termination point at the subscriber's location. It features an Ethernet interface for 10/100 Mbps high-speed data, voice services and IP video, and a coax interface for broadcast video.



The Scientific Atlanta FTTH ONT combines point-to-point high-speed Ethernet connectivity with a video overlay. The FTTH ONT is based on open standards for Ethernet and CATV to work with network equipment from multiple vendors. The unit's coax broadcast video interface offers simple, widely-used connectivity to traditional cable television that will help network operators quickly roll out services by overcoming the hesitation non-technical subscribers might have. In addition, the FTTH ONT features integrated fiber management and built-in power supply, eliminating the need for a cumbersome separate power source.

The unit's optical automatic gain control (AGC) and gain switch allow the technician to easily configure the FTTH ONT's output level without using test equipment. The gain switch is easily accessible for the subscriber to increase the signal output level as more TVs are added, thus reducing the need for additional amplifiers and technician-installed equipment.

The network components within the device include only basic functionalities, i.e., optical/electrical conversion to help minimize technology obsolescence. Moreover, the device has been designed for reliability by using only high-quality parts.

Features

- Two-fiber solution for data and video overlay
- Ethernet interface for 10/100 Mbps high-speed data, voice services and IPTV
- Video overlay for TV/DVB-C/Radio
- Installation friendly built-in fiber management
- High reliability
- Based on established standards – transparent
- AGC based on optical input

Block Diagram

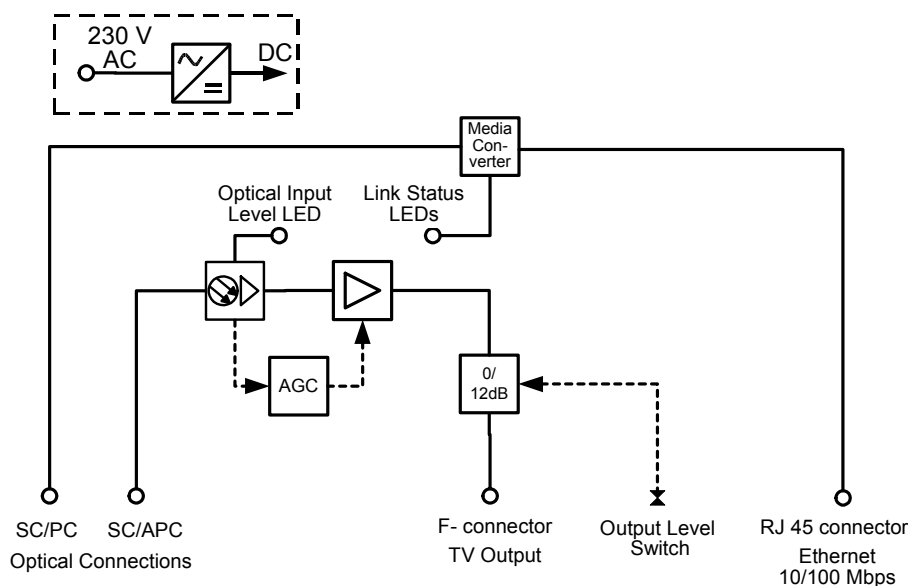

Specifications

Media Converter	Units	90600	Notes
Optical wavelength	nm	Receive 1500 – 1600 Transmit 1310 ± 50	
Max. optical input level	dBm	-3	
Receiver sensitivity	dBm	-33	
Optical output level	dBm	-13 → -6	
Optical connector		SC/PC	
Electrical connector		RJ45	
Speed, optical	Mbps	100	
Speed, electrical	Mbps	10/100	1
Electrical interface functionality		Autocross Autosense half-/full duplex	
Packet size		Support VLAN tags and, jumbo packets up to 1916 bytes	
LEDs		FX: connected: green FX: traffic: flashing green TX: connected: green TX: traffic: flashing green	2 3
Analog Receiver			
Optical wavelength	nm	1270 - 1620	
Max. optical input level	dBm	6	
Operational optical input level	dBm	-10 → -3	
Optical connector		F-female	
RF bandwidth	MHz	40 – 1000	
Input noise current	pA√Hz	≤ 5.5 ≤ 6.5	4 5
RF output level	dBμV	84 @ 862MHz	6
Switch able attenuator	dB	0/12	7
RF output level tolerance	dB	± 2	8
RF output tilt	dB	4 ± 1 @ 40-862 MHz	

RF output return loss	dB	≤ 16 @ 45-862 MHz ≤ 12 @ 862-1000 MHz	
CTB ≤ 60 dB, EN50083-3	dBμV	84 @ 862MHz	
CSO ≤ 60 dB, EN50083-3	dBμV	84 @ 862MHz	
Optical input power meter, tri-color LED	dBm	≤ -10: red -10 → -3: green ≥ -3: yellow	
General			
Supply voltage	V AC	187 - 250	
Operating temperature range	°C	0 - +55	
Power consumption	W	≤ 6	
Dimensions: H x W x D	mm	245 x 180 x 50	
Housing		Polycarbonate	
Weight	Kg	1.1	
Cover		RAL Color 9003	
Notes:			
1) Auto sense			
2) Fiber side			
3) TX: RJ45 side			
4) 45 - 862 MHz, 25°C, typical value			
5) 862 - 1000 MHz, 25°C, typical value			
6) High-gain, OMI 4%, 1550nm, Pin= -10 → -3dBm, AGC on			
7) End-customer accessible			
8) 40 – 862MHz, optical level -10 to -3 dBm, 0 - 45°C			

Ordering Information

Description	Part Number
FTTH ONT	A90600.102
Fiber management part	A90600.10
Active part	A90610.102



Scientific Atlanta is a registered trademark of Scientific-Atlanta, Inc.
Cisco, Cisco Systems, and the Cisco Systems logo are registered trademarks of Cisco Systems, Inc. and/or its affiliates in the U.S. and certain other countries.
All other trademarks shown are trademarks of their respective owners.
Specifications and product availability are subject to change without notice.
© 2006 Scientific-Atlanta, Inc. All rights reserved.

Americas
1-800-722-2009 or 770-236-6900
www.scientificatlanta.com

Europe & Asia
+32 56 445 445
www.saeurope.com

Part Number 7009999 Rev A
June 2006